

MEMS Soil Monitor

PROJECT PLAN

Team #5

Client

Dr. Halil Ceylan

Advisers

Shuo Yang & Dr. Yang Zhang

Team Members

Nathan Coonrod (Report Manager and Hardware Lead)

Kyle Kehoe (Communications Manager and Testing Lead)

Jacob Verheyen (Meeting Facilitator and Hardware Designer)

David Severson (Web Master and Reliability Lead)

Sok-Yan Poon (Timeline Manager)

Team Email

sddec18-05@iastate.edu

Team Website

sddec18-05.sd.ece.iastate.edu

Revised: 4/22/18 (v 0.0.3)

Table of Contents

1	Introductory Material	5
1.1	Acknowledgement	5
1.2	Problem Statement	5
1.3	Operating Environment	5
1.4	Intended Users and Intended Uses	5
1.5	Assumptions and Limitations	6
1.6	Expected End Product and Other Deliverables	6
2	Proposed Approach and Statement of Work	6
2.1	Objective of the Task	6
2.2	Functional Requirements	7
2.3	Constraints Considerations	7
2.4	Previous Work And Literature	7
2.5	Proposed Design	9
2.6	Technology Considerations	11
2.7	Safety Considerations	11
2.8	Task Approach	12
2.9	Possible Risks And Risk Management	12
2.10	Project Proposed Milestones and Evaluation Criteria	13
2.11	Project Tracking Procedures	13
2.12	Expected Results and Validation	13
2.13	Test Plan	14
2.14	Laboratory and testing Standards	14
3	Project Timeline, Estimated Resources, and Challenges	16
3.1	Project Timelines	16
3.2	Feasibility Assessment	17
3.3	Personnel Effort Requirements	17
3.4	Other Resource Requirements	18
3.5	Financial Requirements	19
4	Closure Materials	19

4.1 Conclusion	19
4.2 References	20

List of Figures

Figure 1: List of Functional Requirements

Figure 2: Proposed Architecture

Figure 3: Capacitance Relation

Figure 4: Moisture Sensing Front End

Figure 5: Software Flow Diagram

Figure 6: Project Task Approach

Figure 7: Test Plan Table

Figure 8: First Semester (Spring 2018) Project Timeline

Figure 9: Second Semester (Fall 2018) Project Timeline

Figure 10: Feasibility Assessment Table

Figure 11: Personnel Hours Estimation

Figure 12: Estimated Financial Costs for Our Project

List of Definitions

BOM: Bill of Materials

CCEE: Construction, Civil and Environmental Engineering

CSV: Comma-Separated Values

DAQ: Data Acquisition System

ECpE: Electrical and Computer Engineering

ETG: Electronics and Technology Group

MEMS: Micro-Electrical-Mechanical Systems

MRC: Microelectronics Research Center

1 Introductory Material

1.1 ACKNOWLEDGEMENT

This project is possible because of the time donated (directly and indirectly) by the students and professors involved. Special thanks goes to Associate Professor Dr. Tuttle, who graciously volunteered his time to help us students recreate MEMS sensors at Iowa State's MRC facilities.

1.2 PROBLEM STATEMENT

The Civil, Construction and Environmental Engineering (CCEE) department at Iowa State wants to utilize MEMS sensors for soil monitoring underneath pavement. Currently, the CCEE department is using expensive, unreliable sensors for monitoring temperature and moisture content of soil underneath roadways. In addition, many of these sensors do not come with data acquisition modules. This leads to researchers spending hours in the field with their own measurement devices collecting data.

The CCEE department wants to utilize a MEMS sensor developed by the Electrical and Computer Engineering (ECpE) department at Iowa State. This sensor is inexpensive and precise, but does not come with a data acquisition system. This project will create a data acquisition system for the MEMS sensors designed by the ECpE department. The system will gather soil moisture and temperature throughout the course of a month, which will be interpreted by the CCEE researchers in order to make decisions.

1.3 OPERATING ENVIRONMENT

The sensor and data acquisition module will be used outside in the harsh Iowa environment. The sensor will be underground and connected to the module through cables. The module will be at the surface to provide access to the SD card and the battery pack.

The sensor will need to have a low propensity to corrode since it will be in the ground for the entire life cycle. The data acquisition module must be able to last one month in an average climate; approximately one month in roughly 60 degrees Fahrenheit will be our "test climate."

1.4 INTENDED USERS AND INTENDED USES

The users of this product will be the researchers from CCEE who are monitoring the soil underneath roads or pavement. The researchers will be gathering data such as temperature change and moisture content change and utilizing that data to make decisions for the Iowa Department of Transportation.

The product is intended to be used in the outdoors. It is to be used only for gathering temperature and moisture changes throughout the course of two to six weeks underneath pavement. This product could also be used to measure temperature or moisture of soil in other settings if needed.

1.5 ASSUMPTIONS AND LIMITATIONS

Assumptions

- There will be four independent channels for sensors
- The unit will have a minimum battery life of one month in average lowa temperatures
- The unit will log data with an SD card
- The range of resistance measurements will be approximately 209-211 ohms
- Capacitance measurement will be in the range of 1-2 pF, with a resolution of 15 fF The cable connecting the sensor to the data acquisition module will be no longer than three feet
- 15 minute sampling period

Limitations

- Limitations (such as voltage input, max output, etc.) will be determined after we meet with the sensor developer.

1.6 EXPECTED END PRODUCT AND OTHER DELIVERABLES

The end product will be a complete DAQ system that can measure resistance and capacitance via a MEMS sensor and store that information in 15 minute intervals for an entire month.

The MEMS sensor is provided to us by the CCEE department, and was developed by the ECpE department. This sensor is able to measure temperature and moisture content.

The output of the sensor will be collected by the team's data acquisition unit. The unit will store that information onto an SD card and be readily available by researchers when they need to access the data.

2 Proposed Approach and Statement of Work

2.1 OBJECTIVE OF THE TASK

The objective of the project is to provide researchers the hardware and software tools to be able to reliably collect soil data with an instrument which is cheaper to scale for large experiments than available off the shelf tools. Researchers are always looking for less expensive, more reliable tools, and the goal is to assist them in creating a tool that will work for their specific use.

2.2 FUNCTIONAL REQUIREMENTS

Requirements
Four independent sensor channels
SD card data logging
Resistance measurement range 209-210 ohms
Capacitance measurement range 1-2 pF
Cable length max 3 ft
CSV output data values
One month battery life in average climate
Minimum temperature resolution of 1 degree Celsius
Minimum capacitance measurement of 15fF
15 minute sample period

Figure 1: List of Functional Requirements

The requirements shown in Figure 1 were provided by the client. The requirements are not listed in any specific order, although some requirements are more important than others, such as battery life, resistance measurement, and CSV output data values. As the project continues, requirements may be added, removed or changed.

2.3 CONSTRAINTS CONSIDERATIONS

Feasibility of all functional requirements will be determined in the project prototyping phase. For all requirements which cannot be reasonably met on the prototype, the team will discuss with the customer the following solutions:

- Change requirement
- Remove requirement
- If dependent on other requirements, relax conflicting requirement

2.4 PREVIOUS WORK AND LITERATURE

Micro-electro-mechanical (MEMS) sensors are devices that can detect and measure different parameters of interest by a combination of mechanical and electrical phenomena. For example, temperature, pressure (strain), moisture, etc. are all able to be measured by MEMS sensors. MEMS sensors take advantage of the material properties they are made of by generating a signal (resistance, voltage, capacitance, etc.), and this signal can be measured and used to get the desired parameter to be measured if one knows how the signal is proportionally related to the parameter. MEMS sensors are commercially available and can be used in many different applications. One specific application is structural health monitoring of civil engineering projects according to a two -volume report titled *Development of a Wireless MEMS Multifunction Sensor System and Field Demonstration of Embedded Sensors for Monitoring Concrete Pavements* written by Ceylan et al.

In the report by Ceylan et al., structural health monitoring (SHM) is an important application for MEMS sensors to be utilized in. MEMS sensors can be embedded in concrete in different civil engineering projects such as bridges and highways to monitor properties of the pavement. Important properties to measure include strain, temperature, and moisture content of the concrete in these structures. By monitoring these important properties, the

appropriate governing body could perform preventative maintenance of roads and bridges to appropriate locations before major damage to the pavement structures shut them down for an extended amount of time. According to Hugo and Epps Martin, traditional SHM methods have not utilized MEMS sensors but rather “full-scale test tracks instrumented with a large number of sensors such as strain gages, pressure cells, displacement gauges, subgrade moisture sensors, etc.” (qtd. in Ceylan).

A specific goal mentioned in the report by Ceylan et al. was to field-test and evaluate commercial MEMS sensors and wireless sensors based on radio frequency identification technology (RFID). This was done on a small section of US 30 highway near Ames, IA, being repaved in May 2013. Sensors were installed within the roadway before it was repaved to measure moisture, temperature, and strain of the pavement. Data was obtained from these sensors over the course of about a year from May 2013, until April 1, 2014. Data was collected a couple of months before opening to traffic, during the summer months, and the winter months. Reliability of the sensors to last for an extended amount of time was a major concern considering the harsh environment of the concrete and climate of Iowa. Of the 27 total sensors installed at the beginning of the project, only 5 total sensors remained on the last day of evaluation in April. Speaking with one of the researchers and authors of the report, Shuo Yang, he emphasized the importance of sensors needing to be reliable in harsh environmental conditions. He also said that the time of installation, per-unit cost of sensors (some in the order of hundreds of dollars), and the cost of data loggers (also in the order of hundreds of dollars) were drawbacks.

The customer has used commercially available data acquisition systems in the past. None of the tested products have been viable for the customer’s application. Below is a brief list of the specific issues with several of the systems previously tested:

ECH2O Datalogger: Public pricing not available

- 5 channels (sensors not included)
- 1-3 year battery life depending on sample rate
- +/-1 degrees Celsius
- +/- 3% moisture content

Sensorion EK-H4: \$388

- 4 channels of temp and humidity sensors
- +/- 3% relative humidity
- +/- 0.4 degrees Celsius

2.5 PROPOSED DESIGN

HARDWARE

The core of the system we are designing will be an Adafruit Feather, powered by an Arduino-compatible microcontroller. It will log our resistance and capacitance measurements and store them in a .csv file format. There are more than enough analog input pins on the Feather to take all of our measurements. The challenging part of this project will be measuring resistance and capacitance with a high enough resolution across a wide temperature range. The overall proposed architecture is shown in Figure 2.

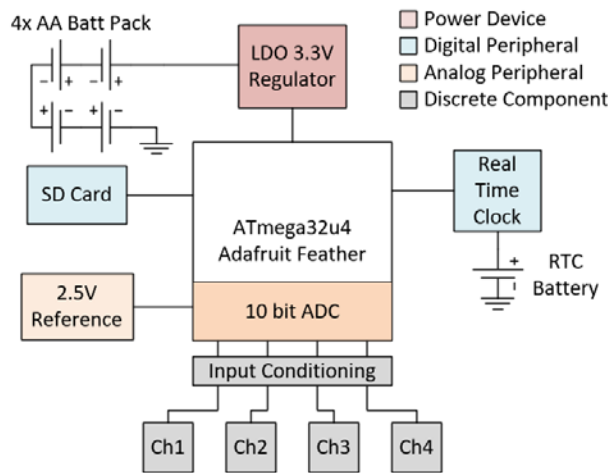

Figure 2: Proposed Architecture

The output of the temperature sensor will only vary by a few ohms over a wide temperature range. This makes it very challenging to accurately measure temperature. We plan to measure resistance using a simple voltage divider circuit. We will have a resistor of a known value in series with our temperature sensor, powered by a precision voltage reference. If we know the voltage between the temperature sensor and the resistor, we can calculate the resistance of the temperature sensor. Once we characterize our temperature sensors, we will know the relationship between temperature and resistance, and we will be able to calculate temperature based on that resistance value.

The output of the moisture sensor will only vary by a few picofarads over a wide moisture range. This will also be very challenging to measure. One potential solution for measuring moisture is designing a precision analog circuit to accurately measure capacitance. It works by applying a triangle wave to the capacitor and measuring the current through the capacitor. That current is then converted to a voltage using a current to voltage converter with a square wave output. A peak detector will continuously track the maximum amplitude of that square wave, and the amplitude can be directly related to the capacitance using the following relation in Figure 3.

$$C = \frac{I}{dV/dt}$$

Figure 3: Capacitance Relation

Traditionally, many capacitance meters use a resistor to create an RC filter which can be measured to determine the capacitor under test. However, when measuring capacitors as small as this application requires, the RC time constant gets small enough that the sampling ADC must operate at a minimum of tens of megahertz, for the resolution we require, hundreds of megahertz would be required. But thanks to the above relation, we can put a voltage source across the capacitor which has a known slope (dv/dt) and simply measure current. The magnitude of the currents measured is in the single μA so a carefully designed amplifier is required. Some of the features required of this stage for acceptable performance is ultra-low input bias current, near ideal input offset voltage, bandwidth $>1MHz$, and rail to rail output. The final stage, composing of the peak detector, is much simpler and is easily designed using readily available op amps. A schematic of the moisture sensing front end is shown in Figure 4 below.

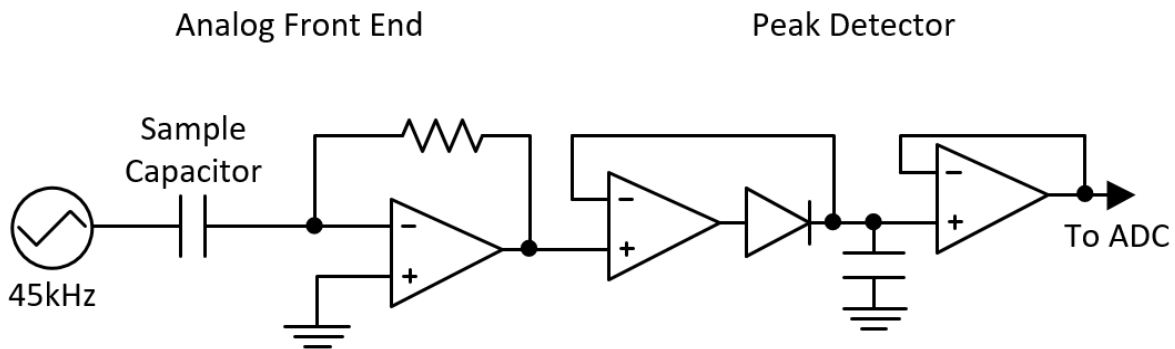

Figure 4: Moisture Sensing Front End

It is possible that the hardware limitations of the Feather will not allow the full requirements to be met, but with a higher resolution ADC, higher tolerance voltage reference, and good analog design practices, the full requirements can almost certainly be met. To reduce this risk, we have intentionally prototyped in “modules” which allow us to completely design one or more aspects of the prototype without requiring a completely new design.

SOFTWARE

The software running on the Feather will follow the flow diagram shown in Figure 5. The final battery life of the product will almost entirely depend on efficient and thorough software. Hardware will be present which allows the software to control the analog front end in order to shut it down when not required. Analysis detailed in the project design report has determined that the average power consumption is heavily dependent on the microcontroller sleep current because the sample period is so large. It will be important to take every measure possible to shut down unneeded peripherals and features in the microcontroller before entering sleep mode in order to draw as little current as possible. In order to generate the interrupt which will wake the microcontroller at every sample period, a real time clock with an internal alarm feature will be utilized. Using a slow speed serial protocol such as I2C or SPI the microcontroller will program an alarm, enter sleep mode, and monitor the bus for the resulting interrupt to sample and repeat.

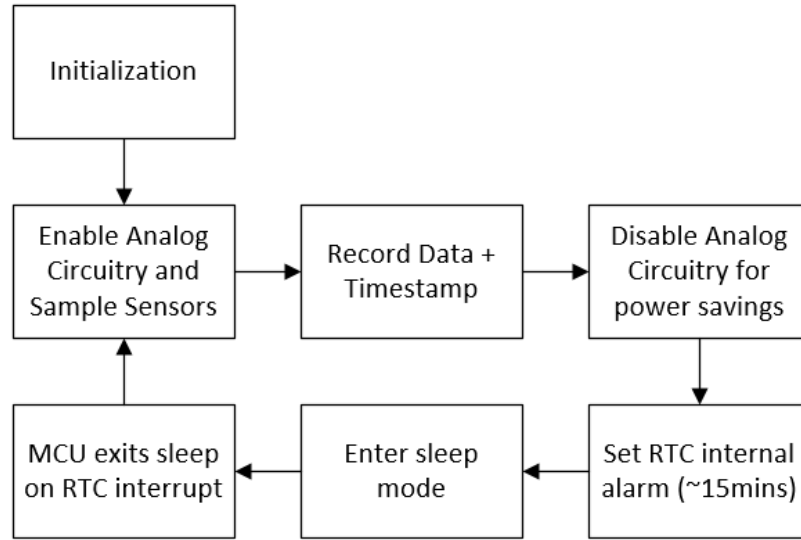

Figure 5: Software Flow Diagram

2.6 TECHNOLOGY CONSIDERATIONS

This project involves embedded hardware design and is limited to the performance of commercially available microcontrollers, ADCs, and other electrical components. It has been identified by the team that the resolution required for the project is at the edge of what is possible using readily available hardware.

Furthermore, the development phase of the project will be completed using an Arduino development board which will likely not be able to achieve the required resolution for all requirements. The team will determine as early as possible if requirements are reasonably achievable early in the project and negotiate changes with the customer as needed.

2.7 SAFETY CONSIDERATIONS

Device will be deployed along roadways and left in remote areas for long durations. Although no safety requirements have been imposed by the customer, the team intends the final product to be low-profile but highly visible as to not be a safety concern to vehicles or equipment when deployed in the field.

2.8 TASK APPROACH

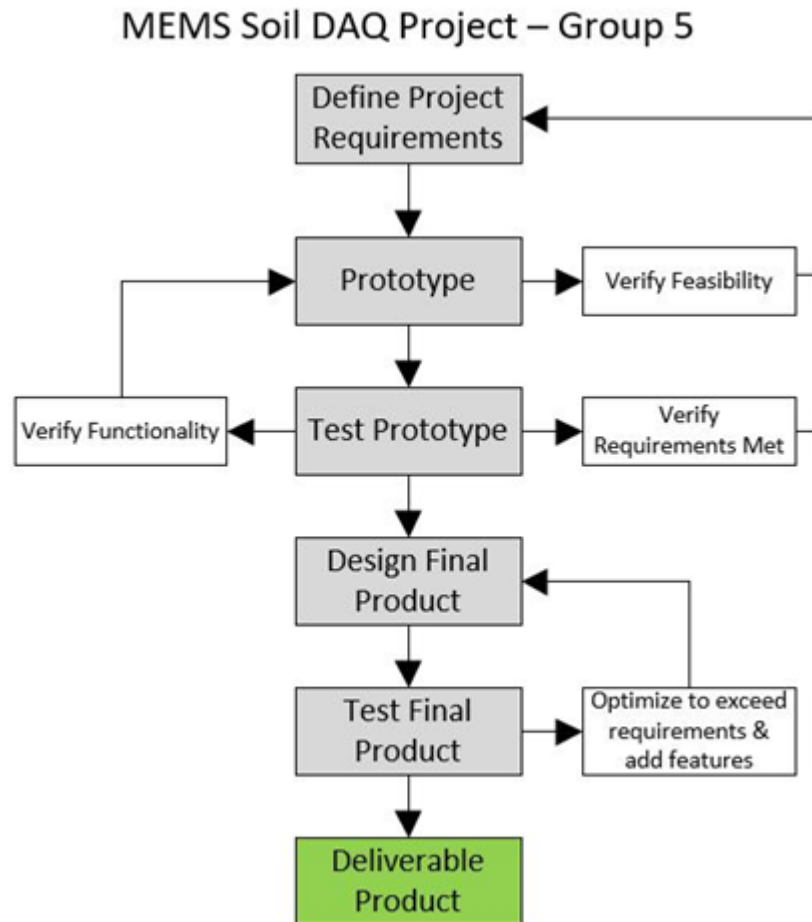

Figure 6: Project Task Approach

Our general methodology for approaching tasks and accomplishing our end goal is shown in Figure 6. The flow diagram shows that we started off by defining project requirements and then branches out into various loops. A milestone for the first semester of senior design is to test a prototype of our data acquisition system that meets all requirements. If everything goes according to plan, the second semester will be spent designing a final and more refined product than a prototype that can be an improved version of the prototype.

2.9 POSSIBLE RISKS AND RISK MANAGEMENT

The team has identified the following aspects of the project as the most prone to add project risk:

- Required resistance resolution of 1 ohm across all temp and environmental conditions
- Required capacitance resolution of 100fF across all temp and environmental conditions

In order to manage this risk, the team will establish early on if the performance the customer requested is feasible. Particularly the capacitance resolution is of concern due to the parasitic capacitance of the long sensor leads. It is likely that calibration will have to occur in order to

minimize the effects of parasitics. The customer is aware of this risk and understands that the resolution requested is outside the ability of common, off-the-shelf data acquisition equipment.

2.10 PROJECT PROPOSED MILESTONES AND EVALUATION CRITERIA

The following are major project milestones and associated criteria for completion:

1. Complete requirements
 - a. All information needed from customer acquired to fully understand application and what a successful final product looks like
2. Functional Prototype
 - a. Prototype fulfills basic functionality of final project in lab environment
3. Prototype Testing
 - a. All requirements met or shown to be feasible
4. Final Design
 - a. All requirements met in lab environment
5. Deliverable Product
 - a. All requirements met and tested across range of intended applications and in the worst conditions required

2.11 PROJECT TRACKING PROCEDURES

Team members track all technical progress on the project using a shared Google Drive and a standard template from which weekly reports are generated and delivered to the customer.

2.12 EXPECTED RESULTS AND VALIDATION

High level testing will include testing by the team, and at later stages by the customer, to verify that operation of the product is intuitive. The final product should be easily operated with the reference of a user manual provided by the designers. A successful product will not only meet all functional requirements but will not require any additional expertise outside of the researchers' application of the product. The described usability will be validated by the customer and any non-intuitive steps simplified or addressed thoroughly in the provided user manual

2.13 TEST PLAN

Each phase of the project will be tested in a different manner to verify performance and reliability is acceptable. We have demonstrated the expected testing requirement for each phase in Figure 7 below.

<i>Project Phase</i>	<i>Testing Requirement</i>
Prototype	Lab testing only using discrete resistors and capacitors as replacement for actual sensors. Verify all requirements achievable and reasonable.
First Revision	Meet and/or exceed all functional requirements in a lab setting and mild conditions of final application.
Deliverable Product	Meet and/or exceed all functional requirements in the worst conditions the device will encounter. Minimum 1 month test.

Figure 7: Test Plan Table

2.14 LABORATORY AND TESTING STANDARDS

As part of this project, a lot of work in laboratories open to undergraduate students will need to be done using a variety of testing equipment and computer software. This work includes characterizing sensor behavior, testing circuit prototypes, etc. Since these laboratories contain expensive testing equipment and must be shared by many students it is of the utmost importance standard laboratory practices are followed to maintain highly functioning test equipment and obtain the most accurate results possible. A list of some important standard protocols our project team will abide by when laboratory or field testing include the following:

- Coordinate any testing work that needs to be done in a private lab (or site) ahead of time with appropriate faculty in charge of the lab (site).
- Be courteous of other project teams in a lab by not interfering with any of their testing work, e.g., computer simulations, circuit(s) under test, etc.
- Only use a piece of equipment if we have the proper knowledge of how to operate. If not, ask for guidance from appropriate faculty or student who does.
- Follow experimental setup as outlined in the testing plan and honestly and accurately record data and results. Do not report overly accurate measurements beyond the scope of the testing equipment's accuracy.
- Properly handle sensitive circuit components, e.g., integrated circuits or sensors, so as not to add unnecessary budget costs and project delays.
- Verify experimental setup will not cause adverse effects on surrounding environment.

These standards are not an exhaustive list of every single protocol we will be following while doing testing; however, we believe they are an excellent reference set of standards to abide by. None of these standard protocols involve behavior that would be deemed unethical by an institution like IEEE and would be addressed in one or more of their standards. The above

standards were influenced completely or in part by the following IEEE standards our group briefly perused:

- IEC 62529-2012(E)(IEEE Std 1641-2010 – IEC 62529 2012(E) Standard for Signal and Test Definition
- IEEE Std 1413-2010 (Revision of IEEE Std 1413-1998) – IEEE Standard Framework for Reliability Prediction of Hardware
- IEEE Std 2700-2017 (Revision of IEEE Std 2700-2014) – IEEE Standard for Sensor Performance Parameter Definitions
- IEEE Std 1332-2012 (Revision of IEEE Std 1332-1998) - IEEE Standard Reliability Program for the Development and Production of Electronic Products

We believe the IEEE standards above are applicable to our project. Specifically, the IEEE Standard for Signal and Test Definition is applicable since there will be signals from sensors our data acquisition system will need to accurately capture to get accurate readings. The IEEE Standard for Framework for Reliability Prediction of Hardware is applicable since we are trying to design a highly reliable system utilizing hardware. Our sensors' performance will need to be characterized hence the IEEE Standard for Sensor Performance Parameter Definitions can be utilized on the project. Finally, the IEEE Standard Reliability Program for the Development and Production of Electronic Products is applicable since we are designing an electronic prototype (product) to be used in research applications that should be very reliable.

3 Project Timeline, Estimated Resources, and Challenges

3.1 PROJECT TIMELINES

Project Planner Spring 2018

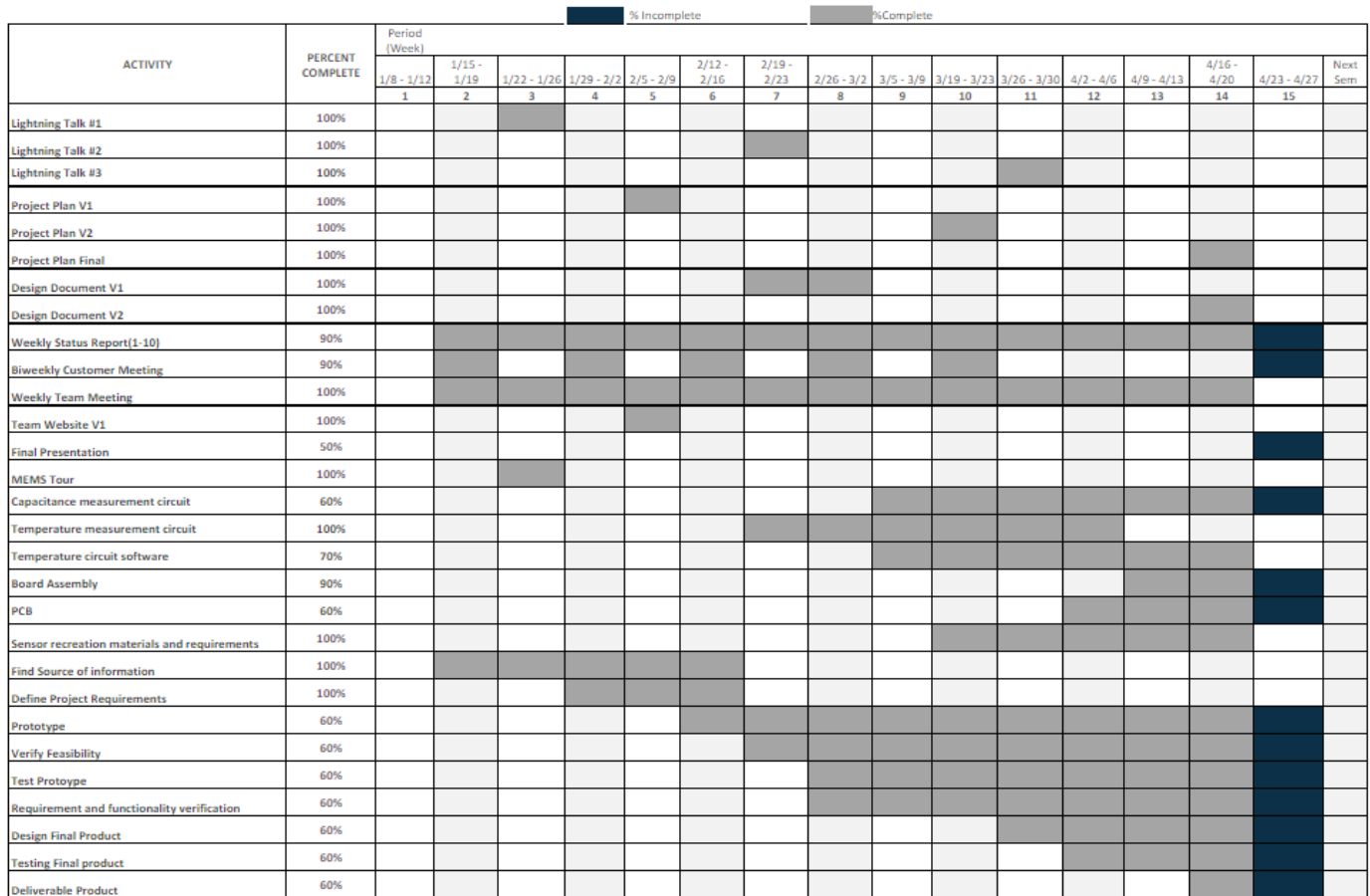

Figure 8: First Semester (Spring 2018) Project Timeline

Project Planner Fall 2018

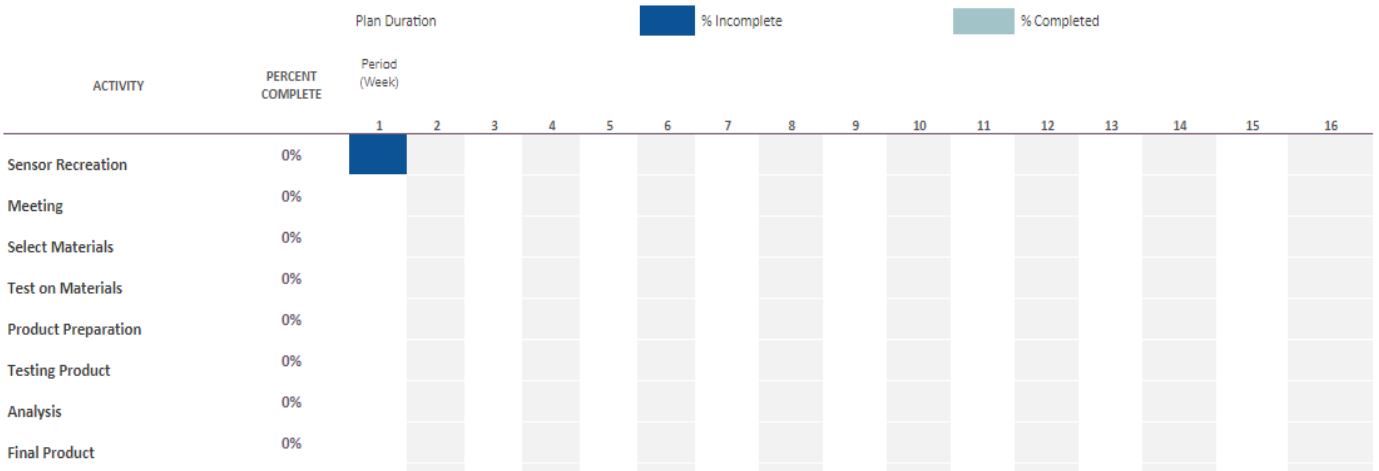

Figure 9: Second Semester (Fall 2018) Project Timeline

Figures 8 and 9 show our project timelines for the first semester and second semester of work respectively on this project. Each timeline is in the form of a Gantt chart with color coded boxes showing the weeks a task is worked on and the corresponding percentage complete. The first timeline for spring 2018 shows tasks that are necessary for our first prototype of our data acquisition system to be successful at the proof-of-concept level. The second timeline for fall 2018 shows tasks that are necessary for a more refined final product to be successful. The tasks in the second timeline encompass recreating sensors on wafer and implementing with our data acquisition system, characterization of sensors, field testing, etc.

3.2 FEASIBILITY ASSESSMENT

The feasibility of this project is high. There are numerous factors that affect feasibility of this project including time and schedule, cost, complexity, and resources. We have summarized each criterion below in Figure 10 and why the criterion can be met.

Feasibility Criterion	Brief Description
Time and Schedule	We are given two semesters in senior design to formulate a project plan and design document to carry out to completion. This should allow plenty of time to develop a working prototype and final product.
Cost	We have no pressing budgetary constraints; however, we are keeping cost in mind and doing our best to find a minimal cost solution for our problem.
Complexity	The complexity of the project is a broad category that encompasses the constraints and specifications our end-product needs to meet. We believe with our skillsets, knowledge, and resources we can create a satisfactory solution that meets the requirements of the project.
Resources	Resources include any material objects we need to make a functional prototype of the project and final solution. There are various labs at Iowa State that can be utilized to gain access to necessary testing equipment, software, etc. Anything we don't have access to can be purchased through ETG.

Figure 10: Feasibility Assessment Table

3.3 PERSONNEL EFFORT REQUIREMENTS

Our team is composed of five electrical engineering students at Iowa State University. We all have similar and complementing skillsets that we will use to complete project tasks. These tasks are

summarized in Figure 11 with the total number of hours needed to do each task exceptionally well. Please note that the hours listed in the figure are for both semesters we students are in the senior design class at Iowa State University. The estimated times were assuming two 14-week semesters of work with about 5 hours of availability each week for each student to work on the project on average. This means 700 discretionary hours would be available. However, we students have other time commitments and won't always have the same availability each week, so we cut that estimate by approximately half to try and account for other time commitments.

Personnel Hours Estimate	
Task	Hours
Design and Simulation	40
Prototyping and Testing	40
PCB Design	20
PCB Fabrication	N/A
Soldering and Assembly	20
Overhead	280
Total	400
Note: PCB Fabrication will be done by a 3rd party vendor	

Figure 11: Personnel Hours Estimation

3.4 OTHER RESOURCE REQUIREMENTS

To reach our end goal of creating a 4-channel data acquisition system, we will need to buy necessary hardware we don't already have available. In addition, the final design will need to have a weather-proof enclosure to withstand Iowa's outdoor weather conditions. Depending on dimensions of our final product and how much more expensive it is to make our enclosure weather-proof, the cost of the enclosure won't be exactly known. We estimate the enclosure will cost around \$30 given that we anticipate our final printed circuit board to be quite small. Our expected future costs are a projection based on the BOM we have used for a couple of our prototypes. The costs mentioned previously are broken down in Figure 12 below. The total amount of \$346.00 is well below our target budget goal of spending no more than \$500.00 on this project.

Project Cost Estimate	MATERIAL COST (\$)	
	<u>Current Expenses (as of 4/22/18)</u>	
Procure Prototyping Hardware		186.00
<u>Projected Future Expenses</u>		
Enclosure		30.00
Procure Final Hardware		130.00
Total		346.0

Figure 12: Estimated Financial Costs for Our Project

This project will require software as well to design, simulate, and program our data acquisition system. We do not foresee any software costs since we already have access to appropriate software in computer labs on campus or can download any necessary software on our personal computers for free.

3.5 FINANCIAL REQUIREMENTS

The financial requirements are pending. The resources for this project will come from the Senior Design budget first. If needed, the CCEE department will allow for funding throughout the project.

4 Closure Materials

4.1 CONCLUSION

Structural health monitoring of civil construction projects is an important application area to help maintain and improve the life-cycle of civil infrastructure projects. The complexity of monitoring any pavement structure is apparent with the specific small section of repaved roadway on US 30 near Ames presenting challenges to researchers in May of 2013. Commercial sensors used on the project were unreliable overall with a high rate of failure within about 1 year of the sensors being installed. In addition, the cost of implementing the sensors and their corresponding data acquisition systems (data loggers) was high.

The end goal of this project is to develop a DAQ system that can interface with MEMS sensors developed by the ECpE department at Iowa State. This data acquisition system needs to meet various constraints including high resolution measurement of resistance and capacitance to measure temperature and moisture content of soil respectively and withstand harsh environmental conditions underground in Iowa's climate.

Our project team has started work on this project by defining requirements and scope of the project. These requirements are ideal requirements for the final product but are subject to change if testing indicates a constraint is not realistic. We have developed a flow process to reach our goal of designing and building a DAQ system. This includes defining requirements of the project, prototyping a solution, testing the prototype and refining, designing a final product, and testing and refining the final product.

The anticipated solution will be a system using embedded hardware and Arduino software. Specifically, an Arduino Uno's analog pins will be utilized to interpret an input signal provided by the MEMS sensors and any necessary measurement circuitry. Programming can be done in Arduino's integrated development environment, which is straightforward and intuitive to use. There is a sufficient number of analog pins on the Arduino Uno to meet the four independent measurement channels requirement. An SD card can be used as a memory unit to store the data on-chip and a researcher can then obtain the data by connection a computer to the module that will be near the surface.

4.2 REFERENCES

1. Ceylan, Halil; Yavas, Seval; Dong, Liang; Jiao, Yueyi; Yang, Shuo; Kim, Sunghwan; Gopalakrishnan, Kasthurirangan; and Taylor, Peter, "Development of a Wireless MEMS Multifunction Sensor System and Field Demonstration of Embedded Sensors for Monitoring Concrete Pavements, Volume I" (2016). InTrans Project Reports. 219. http://lib.dr.iastate.edu/intrans_reports/219